

**NEW**

## PENDO

### Rope Supported LED Light Fitting with variable setting of the luminous flux

#### Series 49 ... VARIO

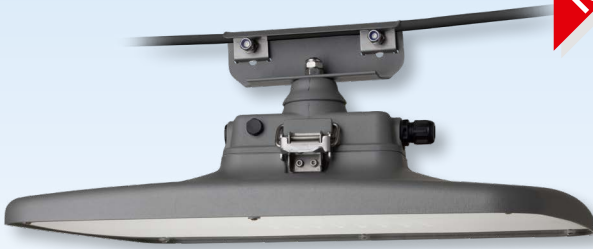

#### Applications:

Through, collecting and main roads etc.

#### Design:

**Housing:** Die-cast aluminium, 2-parts, powder coated in DB 702 (mica-iron paint, grey). **Lower section** with LED-Module, optics, glass cover and ECG, tool-free hingeable and detachable. **Upper section** with bracket, adjustment of inclination, cable entry with pressure compensation system. **Glass cover:** Flat safety glass, impact

resistance IK10.

**Light distribution:** Symmetrical wide beam.

**Switch** for setting the luminous flux of the luminaire.

**Connecting terminal:** With plug-in connection in junction box between upper and lower section, tool-free separation of upper and lower section.

**Mounting:** Stainless steel. Turnable (all directions) and adjustable by 15°, mountable on ropes of 6 - 12mm diameter.

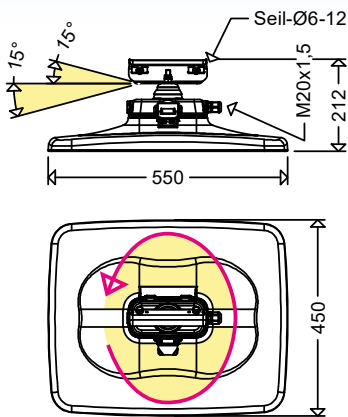

#### Electrical design:

**LED module:** 4,000K or 3,000K,  $R_a > 70$ , service life  $L_{90} > 100,000h$ , Zhaga compliant

**ECG:** 220-240V, 50-60Hz, Surge voltage resistance 10kV, overload and short circuit protection.

#### Light control:

On request, the luminaires are also available with the following configurations:

**Output reduction with control phase (LR):** For reducing the luminous flux to 50% at times of low traffic density. Control phase (LST) required. Switching via control phase (LST = 230V: 100%; LST = 0V: 50%). Alternative dimming levels possible.

**Output reduction without control phase (LA):** Autarkic dimming. Reduced operation 50% between 22:00 and 4:00h CET or 23:00 and 5:00h CEST, also available with deviating times and with alternative dimming steps.

#### Digital dimming with DALI interface (DIMD)

**Constant luminous flux function (CL):** Luminous flux is kept on a constant level over the entire service life of the LED-modules.

#### Options:

- 2,200K, light colour 722 (approx. 15% lower luminous flux)
- 1,800K, light colour 518 „Amber“ (approx. 45% lower luminous flux)
- protection class I (SKI)
- adaptive Light EcoTune (ET)
- seawater-resistant version (SWP)
- additional overvoltage protection (OP) in SKI
- inrush current limiter (ESSB)
- 3-point supporting bracket (3P)
- special painting in RAL colours (SL)

#### Outstanding mounting advantage

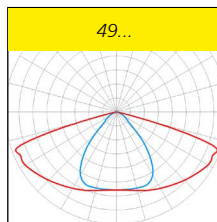

#### Product highlights:

- ECG with surge voltage resistance, reliable due to overload and short circuit protection
- optimized thermal management due to direct adaption of the LED-modules to the die-cast aluminium housing, large cooling surface, excellent heat dissipation
- long-lasting, corrosion resistant die-cast aluminium housing with plain surface. Deposit of greenery and dirt is not possible
- integrated pressure compensation system prevents condensation in the interior
- time- and cost-saving mounting in 2 steps due to tool-free removable lower part of the housing:
  - 1st step:** Hinge upper part with bracket onto the rope and connect the mains.
  - 2nd step:** Hinge lower part, connect isolating plug, shut the housing and close. READY
- universal usage on cross- and longitudinal ropes, inclined ropes or 3-point rope supports (see accessories) due to all-side rotatable and up to 15° inclinable stainless steel bracket
- tool-free disconnection (also electrical!) of the lower part from the upper part allows a comfortable replacement of the components at site or in the workshop, extensive dismantling of the fitting or uncomfortable "over-head working" is not necessary
- efficient and optimal light distribution due to highly efficient lens optics
- homogeneous illumination due to the **Multi-Layer technology** i.e. every individual LED illuminates the whole surface, the light curves of the individual LEDs are overlapping. No dark zones in the road if any single LED would fail and the uniformity of the illumination is kept.
- eco-friendly, no light emission into the upper half-space, ULOR=0
- all versions dimmable to 10% with color temperature up to max. 3,000K fulfill the Dark Sky requirements
- sustainable, control gear and LED-module replaceable by qualified personnel on-site
- future proof by using standardized LED-modules (Zhaga)
- GreenLine luminaire, outstanding sustainable design

Properties, limitations and details for controlling LED-light fittings:

See "Technical Supplement"

All data are correct at the time of printing. Actual technical data can be found under [www.schuch.de](http://www.schuch.de).

Article No.	Type	Connected load [W]	Luminous flux [lm] <sup>1)</sup>	Luminous efficacy [lm/W] (up to)	Substitute for ca. *	Weight [kg] (without packing material)
-------------	------	--------------------	----------------------------------	----------------------------------	----------------------	--

## 49... VARIO



The luminous flux is variably adjustable. The Connected load will change depending on the setting of the luminous flux. In the table you will find examples of settings with reference to common conventional versions. Intermediate values are also possible. Setting table on request.

! All light fittings also available with connected cable (H07RN-F or NYM) in the required length.

### colour temperature 4.000K (light colour 740)

49004 0001	<b>49 L210 VARIO</b>	32 - 140	5.790 - 23.570	181	2 x HST 70 - HME 400	11,8
------------	----------------------	----------	----------------	-----	----------------------	------

### colour temperature 3.000K (light colour 730)

49004 0002	<b>49 L210 VARIO 730</b>	32 - 140	5.500 - 22.390	180	2 x HST 70 - HME 400	11,8
------------	--------------------------	----------	----------------	-----	----------------------	------

Factory setting L210: 140 W; replaces approx. HME 400

\* The given information is for rough orientation only. In each individual case a lighting calculation is necessary. <sup>1)</sup> possible setting range

! Also available with output reduction (LR / LA) or constant luminous flux function (CL) as well as combinations of these functions (CL LR / CL LA).

Optionally also with 3-point mounting (3P)



## Accessories / Spare Parts

Article no.	Type	
49001 9001	<b>ABD 49</b>	cover, pane safety glass clear, for 49...